

Nano-Z Series

Features

- ▶ Ultra-low profile
- ▶ Closed loop control
- ▶ Easy sample holder exchange
- ▶ Compatible with many microscope stages
- ▶ **pico** sensor technology

Typical Applications

- ▶ High speed confocal microscopy
- ▶ High throughput fluorescence microscopy
- ▶ Super resolution microscopy



Product Description

The Nano-Z Series are high precision Z-axis nanopositioners specifically designed to hold slides, chambered slides, cover slips and 35mm petri dishes. The Nano-Z series nanopositioning systems are ideal for single cell fluorescence microscopy, super resolution microscopy and high resolution confocal imaging. The nanopositioning stages have true flexure guided motion and contains internal position sensing. Utilizing proprietary

pico technology, the position sensors provide absolute, repeatable position measurement for closed loop control with sub-nanometer resolution. The Nano-Z series offers smooth, continuous travel with superior resolution and stability for advanced microscopy techniques.

Technical Specifications

Range of motion (Z100)	100 μm
Range of motion (Z200)	200 μm
Resolution (100/200)	0.2/0.4nm
Resonant Frequency	250 Hz
Recommended max. load (horizontal)*	0.5 kg
Body Material	Aluminum
Controller	Nano-Drive®
75mm slide sample holder	PN 158027
35mm Petri dish holder	PN 158037

* Larger load requirements should be discussed with our engineering staff.

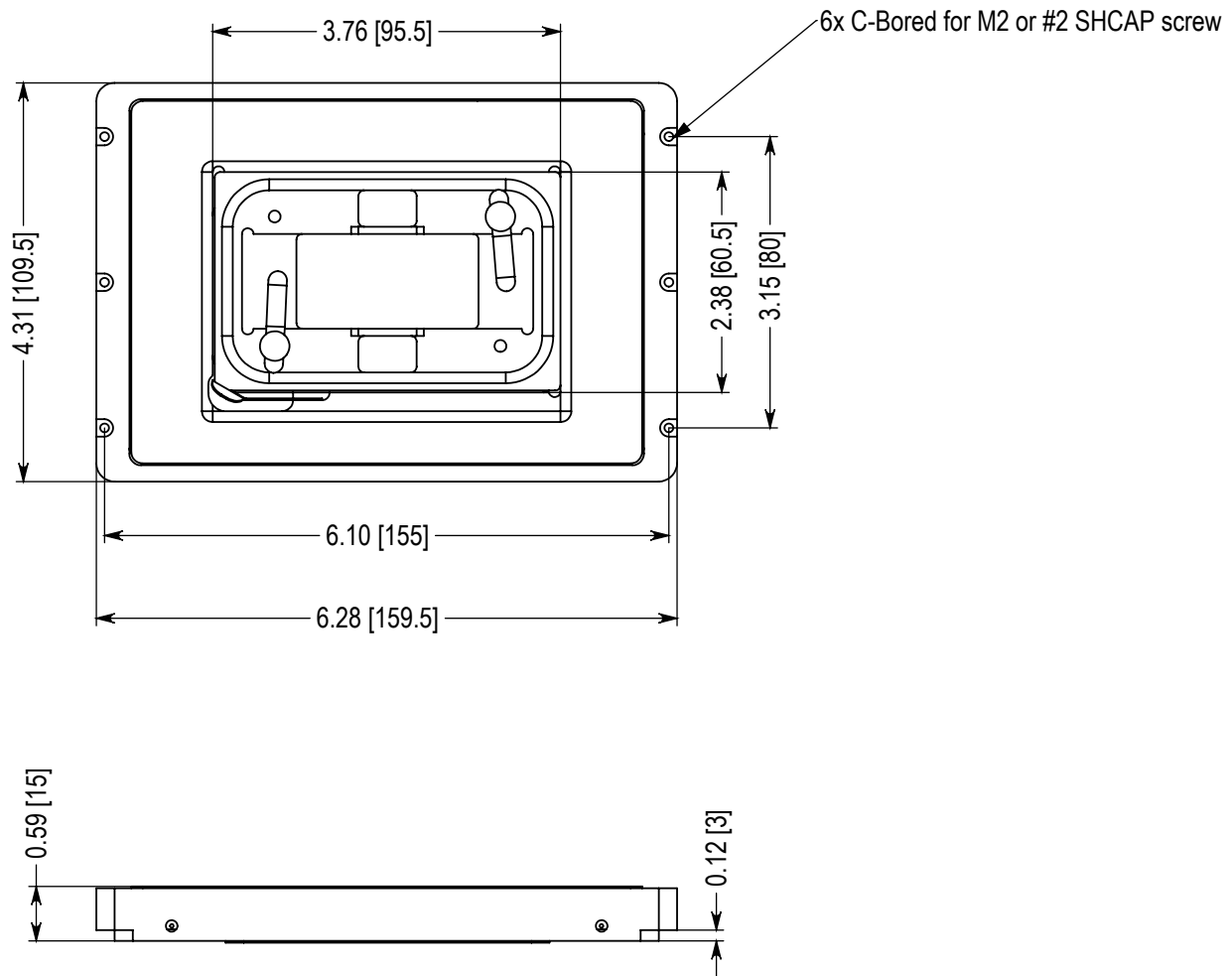

All Dimensions in Inches [mm]